

Metric Internal Toothed Lock Washers Din 6797 J

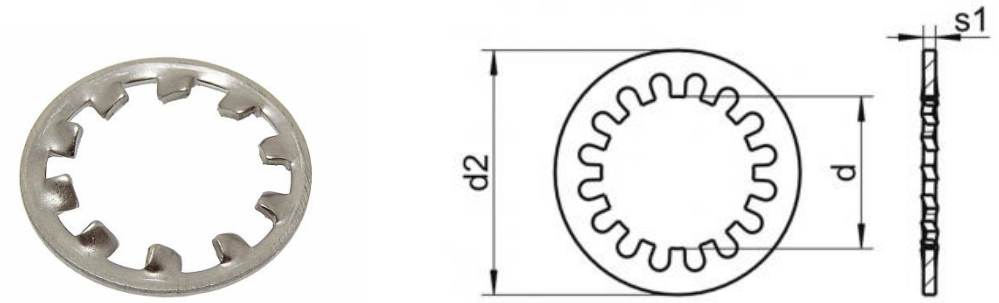

Diameter (d)	d	d2	s1
M3	3.2	6	0.4
M4	4.3	8	0.5
M5	5.3	10	0.6
M6	6.4	11	0.7
M8	8.4	15	0.8
M10	10.5	18	0.9
M12	13	20.5	1.0
M14	15	24	1.0
M16	17	26	1.2
M20	21	33	1.4
M24	25	38	1.5

Shake proof washers provide vibrational resistance by virtue of their internal or external teeth which “bite” into the substrate and nut to provide a locking mechanism. They also provide electrical conductivity, e.g. for earthing terminals on metal cabinets or elsewhere.

Available in various materials and finishes.

Tel: 01234 346242
www.challenge-europe.co.uk
sales@challenge-europe.co.uk

Metric External Toothed Lock Washers Din 6797 A

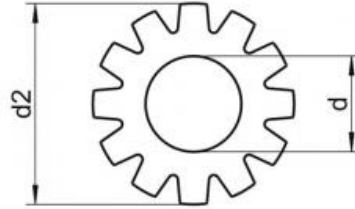

Diameter (d)	d	d2	s1
M3	3.2	6	0.4
M4	4.3	8	0.5
M5	5.3	10	0.6
M6	6.4	11	0.7
M8	8.4	15	0.8
M10	10.5	18	0.9
M12	13	20.5	1.0
M14	15	24	1.0
M16	17	26	1.2
M20	21	33	1.4

Shake proof washers provide vibrational resistance by virtue of their internal or external teeth which “bite” into the substrate and nut to provide a locking mechanism. They also provide electrical conductivity, e.g. for earthing terminals on metal cabinets or elsewhere.

Available in various materials and finishes.

Metric Internal Serrated Lock Washers Din 6798 J

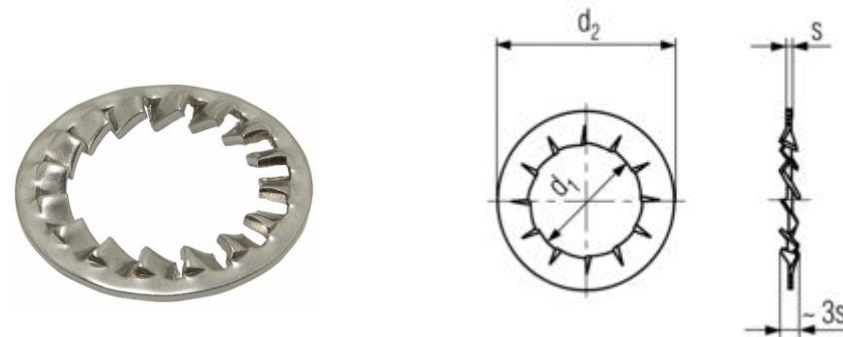

Diameter (d)	d1	d2	s
M3	3.2	6	0.4
M4	4.3	8	0.5
M5	5.3	10	0.6
M6	6.4	11	0.7
M8	8.4	15	0.8
M10	10.5	18	0.9
M12	13	20.5	1.0
M14	15	24	1.0
M16	17	26	1.2
M20	21	33	1.4
M24	25	38	1.5

Shake proof washers provide vibrational resistance by virtue of their internal or external teeth which “bite” into the substrate and nut to provide a locking mechanism. They also provide electrical conductivity, e.g. for earthing terminals on metal cabinets or elsewhere.

Available in various materials and finishes.

Metric External Serrated Lock Washers Din 6798 A

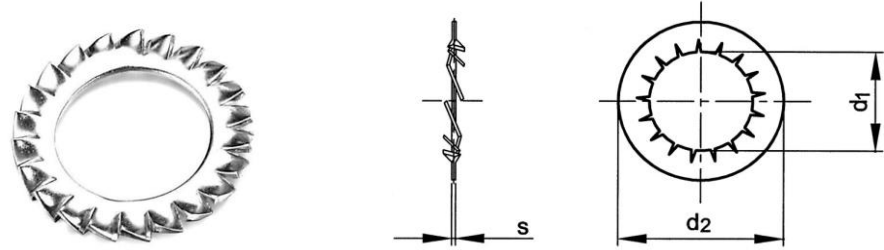

Diameter (d)	d1	d2	s
M3	3.2	6	0.4
M4	4.3	8	0.5
M5	5.3	10	0.6
M6	6.4	11	0.7
M8	8.4	15	0.8
M10	10.5	18	0.9
M12	13	20.5	1.0
M14	15	24	1.0
M16	17	26	1.2
M20	21	33	1.4
M24	25	38	1.5

Shake proof washers provide vibrational resistance by virtue of their internal or external teeth which “bite” into the substrate and nut to provide a locking mechanism. They also provide electrical conductivity, e.g. for earthing terminals on metal cabinets or elsewhere.

Available in various materials and finishes.

Tel: 01234 346242 Fax: 01234 327349
www.challenge-europe.co.uk
sales@challenge-europe.co.uk